

# WISHEK DISC

OPERATOR'S MANUAL

**Offset Models**  
**Tandem Models**

U.S. PATENT NUMBER 4396070

CANADIAN PATENT NUMBER 1181979

DATE OF PURCHASE _____
MODEL NUMBER _____
SERIAL NUMBER _____
CUTTING WIDTH _____



MANUFACTURED BY

**WISHEK MFG. LLC.**

WISHEK, NORTH DAKOTA 58495

# TABLE OF CONTENTS

WARRANTY (All Models).....	3
SPECIFICATIONS (All Models).....	4
SAFETY RULES (All Models).....	5-7
BREAK-IN PERIOD (All Models).....	8
DEPTH CONTROL (All Models).....	8
TRANSPORTING (All Models).....	8
LUBRICATION (All Models).....	9
GANG BOLTS (All Models).....	9
WORKING SPEEDS (All Models).....	9
SCRAPERS (All Models).....	9
GANG ANGLE ADJUSTMENT (All Models).....	10
LEVELING (All Models).....	11
SPRING CUSHION ADJUSTMENT .....	12
ROTARY SCRAPER.....	13
TROUBLE SHOOTING (Tandem Models).....	14
TROUBLE SHOOTING (Offset Models).....	15-16
REPHASING CYLINDERS (Wing Models).....	17
REGISTRATION CARD (All Models)....	Inside Back Cover

## **WISHEK WARRANTY PROGRAM**

Dealer or distributor understands and agrees that Manufacturer extends only the following warranty to customers. In the event Dealer or Distributor extends any additional warranty (such as by enlarging the scope or period of warranty or undertaking a warranty of merchantability or fitness for any particular purpose) or any other obligation whatsoever, Dealer or Distributor shall: (1) be solely responsible therefore; (2) have no recourse against Manufacturer thereof and (3) defend, indemnify and hold Manufacturer harmless against any claim or cause of action whatsoever arising out of, or occasioned by, Dealer or Distributor's extension of said additional warranty or obligation.

## **CERTIFICATE OF GENERAL EQUIPMENT WARRANTY**

Wishek Mfg. L.L.C. warrants new products sold by it to be free from defects in material or workmanship for a period of one (1) year after date of delivery to the first user and subject to the following conditions: Wishek Mfg. L.L.C. obligation and liability under this warranty is expressly limited to repairing or replacing at Wishek Mfg. L.L.C. option any parts that appear to Wishek Mfg. L.L.C. upon inspection to have been defective in material or workmanship. Such parts shall be provided at no cost to the user, at the business establishment of the authorized Wishek Mfg. L.L.C. dealer or distributor of the product during regular business hours. This warranty shall not apply to component parts or accessories of products not manufactured by Wishek Mfg. L.L.C. and which carry the warranty of the manufacturer thereof, or to normal maintenance (such as tune up) or to normal maintenance parts (such as oil filters).

Replacement or repair parts installed in the product covered by this warranty are warranted only for the remainder of this warranty as if such parts were original of said product. **WISHEK MFG. MAKES NO OTHER WARRANTY, EXPRESSED OR IMPLIED, AND MAKES NO WARRANTY OF MERCHANTABILITY OR FITNESS FOR ANY PARTICULAR PURPOSE.**

Wishek Mfg. L.L.C. obligation under this warranty shall not include any transportation charges, cost of installation, duty taxes or any other charges whatsoever, or any liability for direct, indirect, incidental or consequential damage or delay. If requested by Wishek Mfg. L.L.C., products or parts for which warranty claim is made are to be returned transportation prepaid to Wishek Mfg. L.L.C. Any improper use, including operation after discovery of defective or worn parts, operation beyond rated capacity, substitution or parts not approved by Wishek Mfg. L.L.C. or any alteration or repair by others in such a manner as in Wishek Mfg. L.L.C. judgment affects the product materially and adversely, shall void this warranty.

**NO EMPLOYEE OR REPRESENTATIVE IS AUTHORIZED TO CHANGE THIS WARRANTY IN ANY WAY OR GRANT ANY OTHER WARRANTY UNLESS SUCH CHANGE IS MADE IN WRITING, AND SIGNED BY AN OFFICER OF WISHEK MFG. L.L.C. AT ITS HOME OFFICE.**

## **LIABILITY FOR DELAYS**

No liability shall attach to Manufacturer for direct, indirect, incidental or consequential damages or expenses due to loss, damage, detention or delays in delivery of products resulting from acts or delays beyond its control.

## **WARRANTY CLAIMS AND RETURN OF GOODS:**

1. The dealer shall submit each warranty claim to the Company within 30 days after the defective part has been replaced.
2. The dealer shall furnish the company definite proof of delivery date of the machine to the purchaser prior to the Company's honoring any warranty claim.
3. All parts alleged to be defective under the Company's warranty policy shall be made available for examination by the Company, either at the dealer's place of business or factory of the Company, at the Company's option. If examination is to be at the factory, the part shall be returned to the Company with transportation charge prepaid only after the dealer receives specific shipping instructions from the Company.
4. Goods authorized for return to the factory are to be returned by dealer within 30 days from authorization date. Failure to return within the 30-day period will invalidate the warranty claim.

In order to be protected under the terms of the Warranty of Wishek Manufacturing L.L.C., and to avoid delay in processing warranty claims, the original owners name, address and identification numbers of the machine should be registered at the office of Wishek Mfg. L.L.C. within 30 days from from the date of purchase. A registration card is furnished with each machine and can be found on the last page of this booklet.



## **SPECIFICATIONS**

- **6 x 4, 8 x 4, 6 x 8, 6 x 12 Rectangular Tube Frame**
- **3 x 5, 6 x 4, 6 x 12 Rectangular Tube Gang**
- **1-15/16 and 2-3/4 Gang Shaft Diameter**
- **214 and 315 Series Triple Sealed, Heavy Duty Regreasable Gang Bearings**
- **Hitch and Rock Shaft (Running Gear) Connected With Springs**
- **Heavy Duty Blade, Adjustable, or Rotary Scrapers**
- **Cast Blade Spacers**
- **Adjustable Gang Angle, Front And Rear (Smaller Models)**
- **6 - Bolt, 8 - Bolt, or 10 - Bolt Hubs**

## **BLADE SPACING**

- **22" Blade Diameter Models --- 9" Spacing (Front & Rear)**
- **24" Blade Diameter Models --- 10" Spacing (Front & Rear)**
- **28" Blade Diameter Models --- 11" Spacing (Front & Rear)**
- **30" Blade Diameter Models --- 13" Spacing (Front & Rear)**
- **32" Blade Diameter Models --- 13" Spacing (Front & Rear)**
- **36" Blade Diameter Models --- 18" Spacing (Front & Rear)**

★ **Wishek Manufacturing L.L.C. is continually improving its product line. Therefore, we reserve the right to make these improvements without prior notice and without changes on previous models.**

 <h1 style="margin: 0;">WARNING</h1>	
	<p>To prevent Serious Injury or Death:</p> <ul style="list-style-type: none"> <li>• Avoid unsafe operation or maintenance.</li> <li>• Do not operate or work on this machine without reading and understanding the operator's manual.</li> <li>• If manual is lost, contact your nearest dealer for a new manual.</li> </ul> <p style="text-align: right; font-size: small;">105235</p>



This symbol is used to call attention to safety precautions that should be followed by the operator to avoid accidents. When you see this symbol, ***HEED ITS WARNING!***



## REMEMBER:

**Your best assurance against accidents is a careful and responsible operator. If there is any portion of this manual or function you do not understand, contact your local authorized dealer or the manufacturer.**



### BEFORE OPERATION:

- Carefully study and understand this manual.
- Do not wear loose-fitting clothing which may catch in moving parts.
- Always wear protective clothing and substantial shoes.
- Keep wheel lug nuts or bolts tightened to specified torque.
- Assure that agricultural implement tires are inflated evenly.
- Give the unit a visual inspection for any loose bolts, worn parts or cracked welds, and make necessary repairs. Follow the maintenance safety instructions included in this manual.
- Do not use the unit until you are sure that the area is clear, especially children and animals.
- Don't hurry the learning process or take the unit for granted. Ease into it and become familiar with your new equipment.
- Practice operation of your equipment and its attachments. Completely familiarize yourself and other operators with its operation before using.
- The manufacturer does not recommend usage of a tractor with the ROPS removed.
- Move tractor wheels to the widest recommended settings to increase stability.
- Securely attach to towing unit. Use a high strength, appropriately sized hitch pin with a mechanical retainer and attach safety chain.
- Do not allow anyone to stand between the tongue or hitch and the towing vehicle when backing up to the equipment.



### DURING OPERATION:

- **SAFETY CHAIN** — If equipment is going to be transported on a public highway, a safety chain should be obtained and installed. Always follow state and local regulations regarding a safety chain and auxiliary lighting when towing farm equipment on a public highway. Be sure to check with local law enforcement agencies for your own particular regulations. Only a safety chain (not an elastic or nylon/plastic tow strap) should be used to retain the connection between the towing and towed machines in the event of separation of the primary attaching system.
- Install the safety chain by crossing the chains under the tongue and secure to the draw bar cage or hitch or bumper frame.
- Beware of bystanders, **particularly children!** Always look around to make sure that it is safe to start the engine of the towing vehicle or move the unit. This is particularly important with higher noise levels and quiet cabs, as you may not hear people shouting.
- **NO PASSENGERS ALLOWED** — Do not carry passengers anywhere on, or in, the tractor or equipment, except as required for operation.



### **DURING OPERATION:**

- Keep hands and clothing clear of moving parts.
- Do not clean, lubricate or adjust your equipment while it is moving.
- When halting operation, even periodically, set the tractor or towing vehicle brakes, shut off the engine and **remove the Ignition key.**
- Pick the levellest possible route when transporting across fields. Avoid the edges of ditches or gullies and steep hillsides.
- Be extra careful when working on inclines.
- Maneuver the tractor or towing vehicle at safe speeds.
- Avoid overhead wires or other obstacles. Contact with overhead lines could cause serious injury or death.
- Allow for unit length when making turns.
- Do not walk or work under raised components or attachments unless securely positioned and blocked.
- Keep all bystanders, pets and livestock clear of the work area.
- Operate the towing vehicle from the operator's seat only.
- Never stand alongside of unit with engine running or attempt to start engine and/or operate machine while standing alongside of unit.
- Never leave running equipment attachments unattended.
- As a precaution, always recheck the hardware on equipment following every 100 hours of operation. Correct all problems. Follow the maintenance safety procedures.



### **SAFETY SIGN CARE:**

- Keep safety signs clean and legible at all times.
- Replace safety signs that are missing or have become illegible.
- Safety signs are available from your Distributor or Dealer Parts Department or the factory.



### **TIRE SAFETY:**

- Failure to follow proper procedures when mounting a tire on a wheel or rim can produce an explosion which may result in serious injury or death.
- Do not attempt to mount a tire unless you have the proper equipment and experience to do the job.
- Inflating or servicing tires can be dangerous. Whenever possible, trained personnel should be called to service and/or mount tires.
- Always order and install tires and wheels with appropriate capacity to meet or exceed the anticipated weight to be placed on the equipment.



### **FOLLOWING OPERATION:**

- Do not park equipment where it will be exposed to livestock for long periods of time. Damage and livestock injury could result.
- Do not permit children to play on or around the stored unit.
- Make sure all parked machines are on a hard, level surface and engage all safety devices.
- Wheel chocks may be needed to prevent unit from rolling.



### **HIGHWAY AND TRANSPORT OPERATIONS:**

- Comply with state and local laws governing highway safety and movement of farm machinery on public roads.
- Use approved accessory lighting flags and necessary warning devices to protect operators of other vehicles on the highway during daylight and nighttime transport. Various safety lights and devices are available from your dealer.
- Plan your route to avoid heavy traffic.



## **HIGHWAY AND TRANSPORT OPERATIONS:**

- Adopt safe driving practices:
  - Keep the brake pedals latched together at all times. **NEVER USE INDEPENDENT BRAKING WITH MACHINE IN TOW AS LOSS OF CONTROL AND/OR UPSET OF UNIT CAN RESULT.**
  - Always drive at a safe speed relative to local conditions and ensure that your speed is low enough for an emergency stop to be safe and secure. Keep speed to a minimum.
  - Reduce speed prior to turns to avoid the risk of overturning.
  - Avoid sudden uphill turns on steep slopes.
  - Always keep the tractor or towing vehicle in gear to provide engine braking when going downhill. Do not coast.
  - Do not drink and drive!
- The use of flashing amber lights is acceptable in most localities. However, some localities prohibit their use. Local laws should be checked for all highway lighting and marking requirements.
- When driving the tractor and equipment on the road or highway under 40 kph (20 mph) at night or during the day, use flashing amber warning lights and a slow moving vehicle (SMV) identification emblem.
- Be a safe and courteous driver. Always yield to oncoming traffic in all situations, including narrow bridges, intersections, etc.
- Be observant of bridge loading ratings. Do not cross bridges rated lower than the gross weight at which you are operating.
- Watch for obstructions overhead and to the side while transporting.
- Always operate equipment in a position to provide maximum visibility at all times. Make allowances for increased length and weight of the equipment when making turns, stopping the unit, etc.



## **PERFORMING MAINTENANCE**

- Good maintenance is your responsibility. Poor maintenance is an invitation to trouble.
- Make sure there is plenty of ventilation. Never operate the engine of the towing vehicle in a closed building. The exhaust fumes may cause asphyxiation.
- Before working on this machine, stop the towing vehicle, set the brakes, disengage the PTO and all power drives, shut off the engine and **remove the ignition keys.**
- Be certain all moving parts on attachments have come to a complete stop before attempting to perform maintenance.
- **Always** use a safety support and block the wheels. Never use a jack to support the machine.
- Always use the proper tools or equipment for the job at hand.
- Use extreme caution when making adjustments.
- Never use your hands to locate a hydraulic leak on attachments. Use a small piece of cardboard or wood. Hydraulic fluid escaping under pressure can penetrate the skin.
- When disconnecting hydraulic lines, shut off hydraulic supply and relieve all hydraulic pressure.
- Openings in the skin and minor cuts are susceptible to infection from hydraulic fluid. **If Injured by escaping hydraulic fluid, see a doctor at once. Gangrene can result. Without immediate medical treatment, serious infection and reactions can occur.**
- After servicing, be sure all tools, parts and service equipment are removed.
- Do not allow grease or oil to build up on any step or platform.
- Never replace hex bolts with less than grade five bolts unless otherwise specified. Refer to bolt torque chart for head identification marking.
- Where replacement parts are necessary for periodic maintenance and servicing, genuine factory replacement parts must be used to restore your equipment to original specifications. The manufacturer will not claim responsibility for use of unapproved parts and/or accessories and other damages as a result of their use.
- If equipment has been altered in any way from original design, the manufacturer does not accept any liability for injury or warranty.
- A fire extinguisher and first aid kit should be kept readily accessible while performing maintenance on this equipment.



## **BLADE BREAK-IN PERIOD: (All Models)**

Use slow speeds until the extreme sharp edge is worn off the disc blade.



## **DEPTH CONTROL: (All Models)**

The operating depth of the disc is controlled by a 12-inch stroke double acting cylinder. Install donut style stops over the cylinder shaft for positive depth control. **Use the exact same length stops on all cylinders.**



## **PERFORMING MAINTENANCE**

- Use good judgment when transporting the disc by maintaining complete control of the unit at all times.
- Always use the cylinder lock-up brackets when transporting. Lower the weight of the disc on the lock-up bracket to prevent damaging the hydraulic cylinder.
- Comply with state and local laws governing highway safety and regulations when moving machinery.
- Maximum speed of 25 mph is recommended.







## **LUBRICATION: (All Models)**

All Wishek Mfg. **Gang Bearings** are factory prelubricated, therefore, do not require supplemental grease before service life begins. Relubrication, when administered correctly with the proper quality grease, can increase the life of the bearing substantially. Relubrication should be done **approximately** every 60 hrs. Using **approximately** 6 pumps per bearing with a hand held grease gun.

All other Bearings, pivot points, and hinge points should be greased on a daily basis before service begins.

**Over lubrication of Gang Bearings is a major cause of bearing failure!**

**Do not** use pneumatic or other power lubrication methods.

When selecting a bearing lubricant, Wishek Mfg. recommends **ONLY** a good quality NLGI # 2 460ep or equivalent grease.



## **GANG BOLTS: (All Models)**

The gang bolts must be kept tight. Check the bolts at least once every two (2) hours on a new machine. Loose gang bolts and excessive speed are the most common causes of disc blade failure. Check gang bolts periodically and tighten as necessary.



## **WORKING SPEEDS: (All Models)**

Four (4) to Four and a half (4-1/2) miles per hour (MPH) is the recommended speed for proper tillage. Excess speed will cause the disc to ridge, and will cause blade breakage in rocky fields.



## **SCRAPERS: (All Models)**

The full edge of the scraper should contact the disc blade. Adjust the scraper blade by loosening the bolt that attaches the scraper arm to the hanger tube.



## **CAUTION**

SHUT OFF MACHINE BEFORE REMOVING  
SHIELDS AND/OR ADJUSTING MACHINE.  
REPLACE SHIELD BEFORE OPERATING.

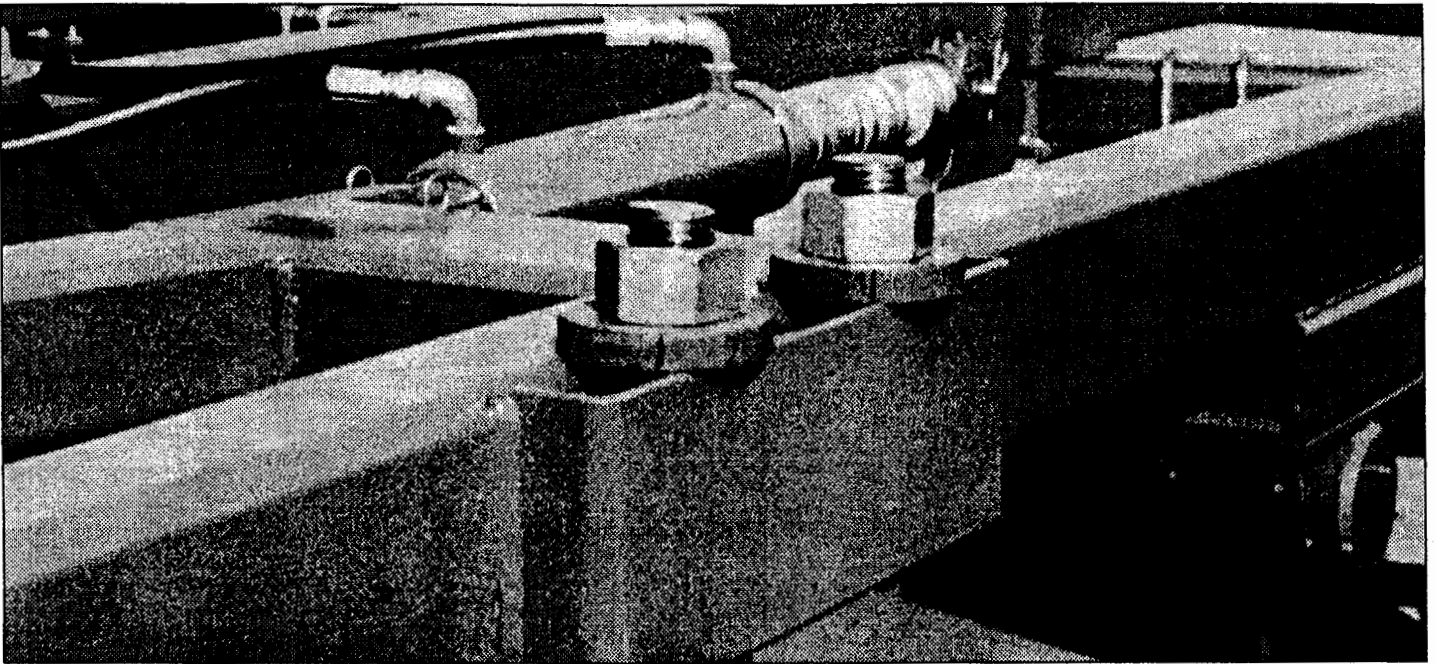

## **GANG ANGLE ADJUSTMENT**

The angle of the gang helps determine the cutting depth of the disc. The front gang should be set at a greater angle than the rear gang for most conditions.

Increasing the angle of cut will cause deeper penetration.

To change the angle of the gangs, loosen the gang tube clamp bolts. With the disc lowered to the ground, pull forward to decrease the angle of the front gang or increase the angle of the rear gang. Back up to increase the angle of the front gang or decrease the angle of the rear gang.

For best leveling, the gangs should be set at the least angle that will allow the desired penetration.

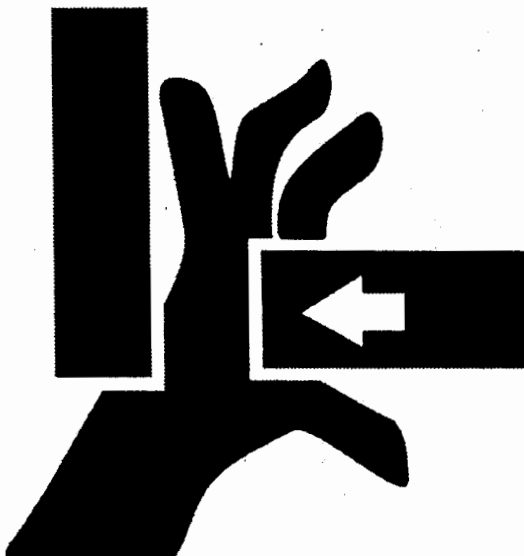

105233

**⚠ DANGER**

**TO PREVENT SERIOUS INJURY OR DEATH:**

- **STAY AWAY FROM UNIT AS IT IS WINGED-UP FOR TRANSPORT.**
- **KEEP OTHERS AWAY.**

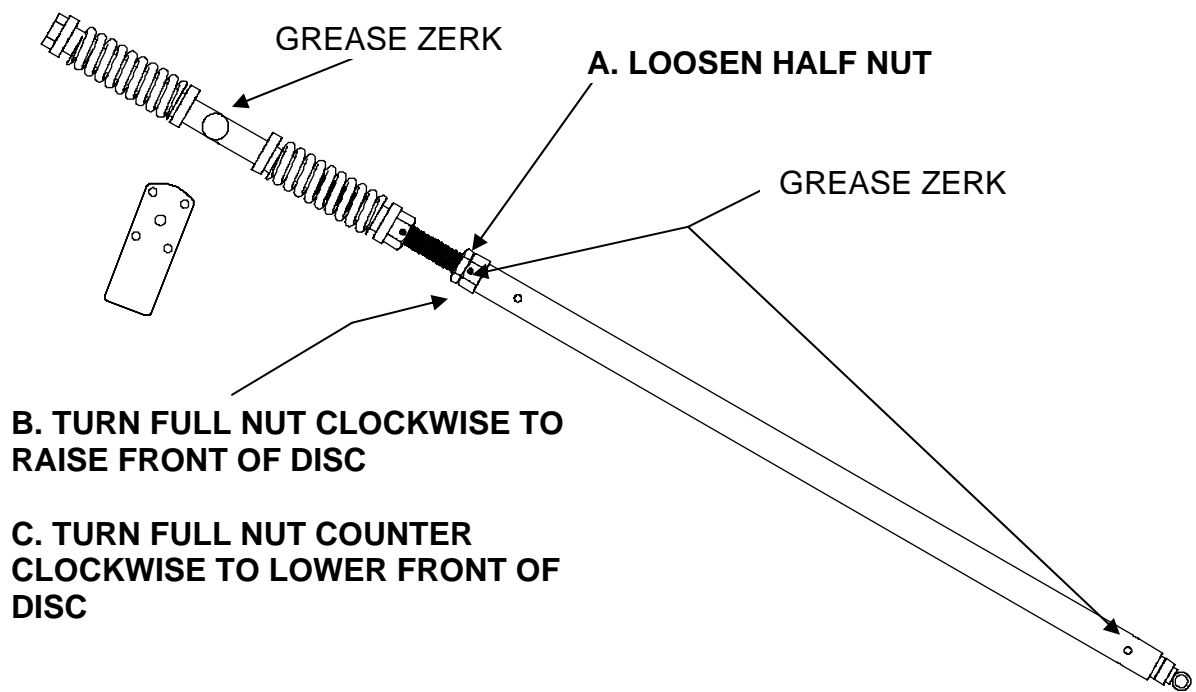

## **LEVELING CRANK (ALL MODELS)**

The spring cushion leveling crank links the drawbar and rockshaft together. This enables the disc to operate at the desired depth while working uneven ground and eases shock in rocky fields. For most soil conditions, the disc should be set so that the frame runs level with the ground.

## PIVOTAL DISC GANG MODEL

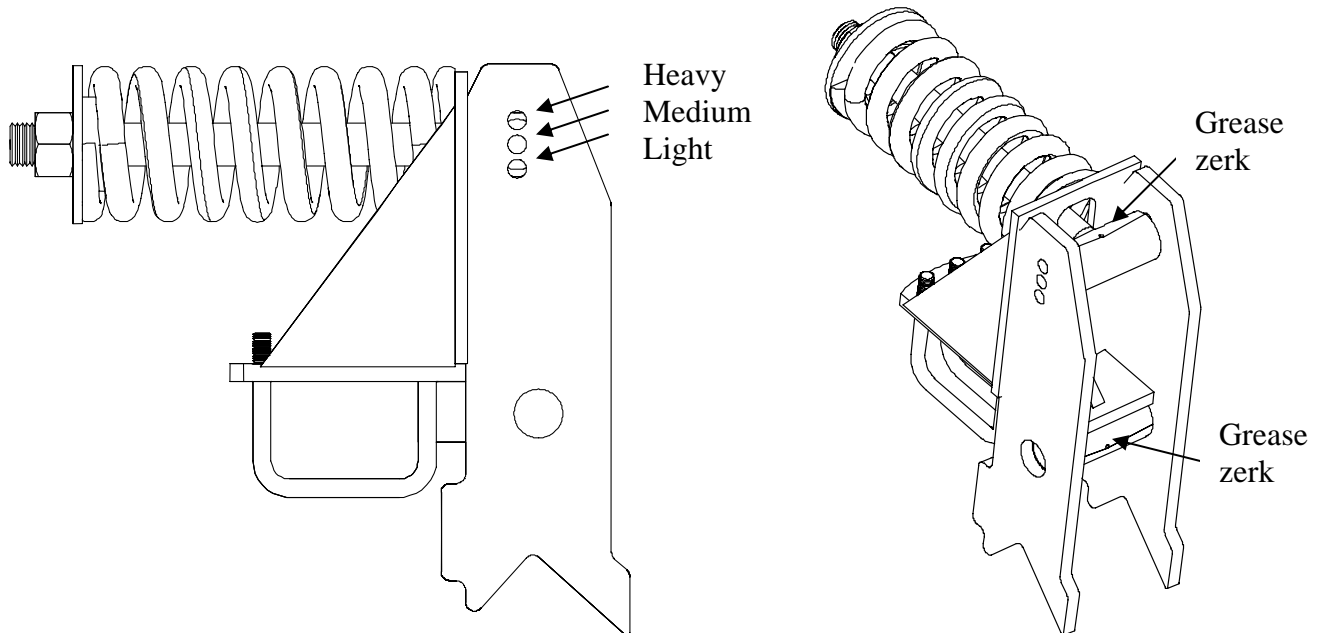

### SINGLE BOLT ADJUSTMENT

Always use the lightest ground pressure setting to get the desired suspension for your soil conditions. An example would be in soil that has been tilled, use the light setting, or maybe the medium setting. In sod or alfalfa ground, use the medium or maybe the heavy setting for extreme conditions.

**⚠ DANGER**

**TO PREVENT SERIOUS INJURY OR DEATH:**

- STAY AWAY FROM UNIT AS IT IS WINGED-UP FOR TRANSPORT.
- KEEP OTHERS AWAY.

105233

# WISHEK MFG ROTARY SCRAPERS

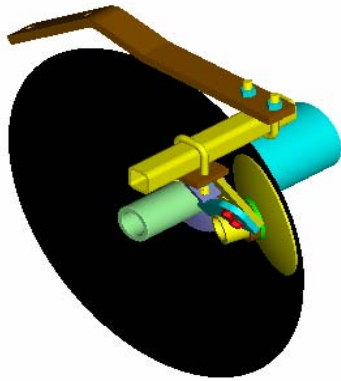

Left Hand Shown

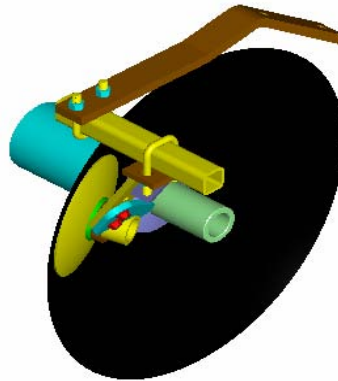

Right Hand Shown

Rotary scrapers are designed to be used in wet and sticky soil conditions where other scrapers have difficulty cleaning disc blades. This new scraper is designed and manufactured to give the purchaser dependable service when used for the purpose for which it was intended and when properly maintained.

## MAINTENANCE

### PERFORM THE FOLLOWING CHECKS DAILY

1. Rotary scraper alignment- Make sure rotary scraper blade contacts disc blade lightly to assure proper cleaning yet allows disc gang to rotate freely.
2. Keep scraper brackets tight. If scraper brackets are allowed to loosen, poor alignment will result and if left unattended brackets could pivot causing spool damage.
3. Check bearings. Firmly wiggle each scraper to check bearings. Loose or failing bearings can cause bearing housing damage.

**SPECIAL NOTE: THESE SCRAPERS ARE INTENDED TO BE USED IN EXTREME CONDITIONS (WET, MUDDY, HEAVY TRASH, ETC.) THESE CONDITIONS WILL PUT EXCESS SIDE PRESSURE ON BEARINGS AND COULD CAUSE PREMATURE BEARING FAILURE. DAILY INSPECTION IS CRITICAL UNDER SEVERE CONDITIONS.**

## TROUBLE SHOOTING -- TANDEM MODELS

### PROBLEM

### REMEDY

**DISC RIDGES DOWN THE CENTER**

Loosen the front or rear U-clamps on the bearing hanger and adjust the section of gang inward or outward depending on need. Adjust the leveling crank to increase or decrease penetration on the rear gang.

**DISC LEAVES STRIP DOWN CENTER**

Loosen the front U-clamps on the bearing hanger and adjust that section of the gang inward until the blades cover the strip, making sure that you adjust the right hand and left hand an equal amount.

**DISC RIDGES ON OUTWARD SIDES**

Adjust the front blades inward and the rear blades outward; or decrease the front or rear gang angle. Travel at a slower speed

**DISC WILL NOT PENETRATE TO DESIRED CUTTING DEPTH**

Increase gang angle, adjust the leveling crank to put more pressure on the front gang. Check hydraulic cylinder, making sure it is closing.

# TROUBLE SHOOTING – OFFSET MODELS

PROBLEM: Offset Disc Runs to the Right

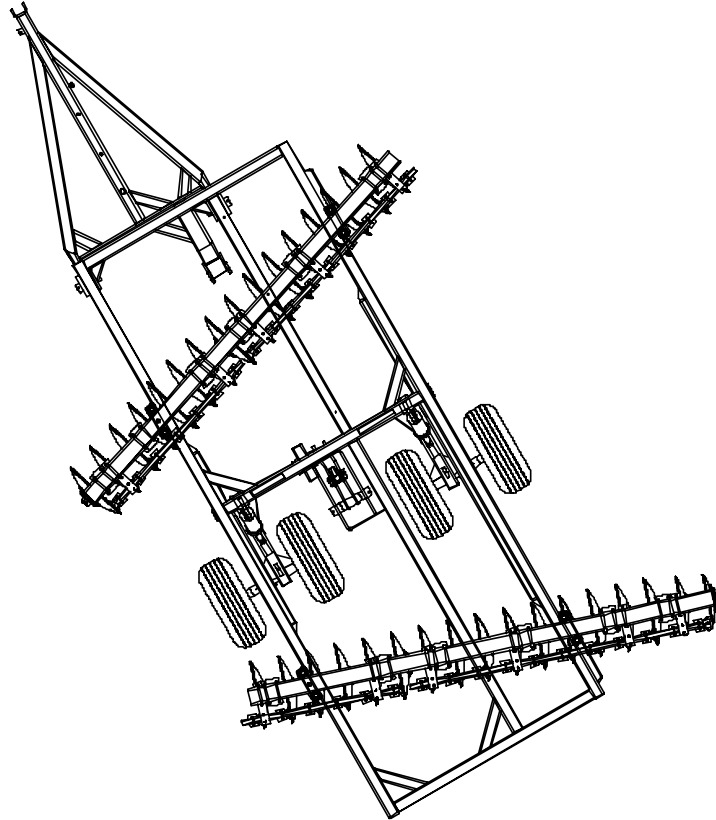

1. Lower front gang and raise rear gang with leveling screw.
2. Increase front gang angle.
3. Decrease rear gang angle.

The offset disc may be turned to the left with the disc in the ground. However, for right hand turns, the disc must be raised out of the ground.

## TROUBLE SHOOTING – OFFSET MODELS

PROBLEM: Offset Disc Runs to the Left

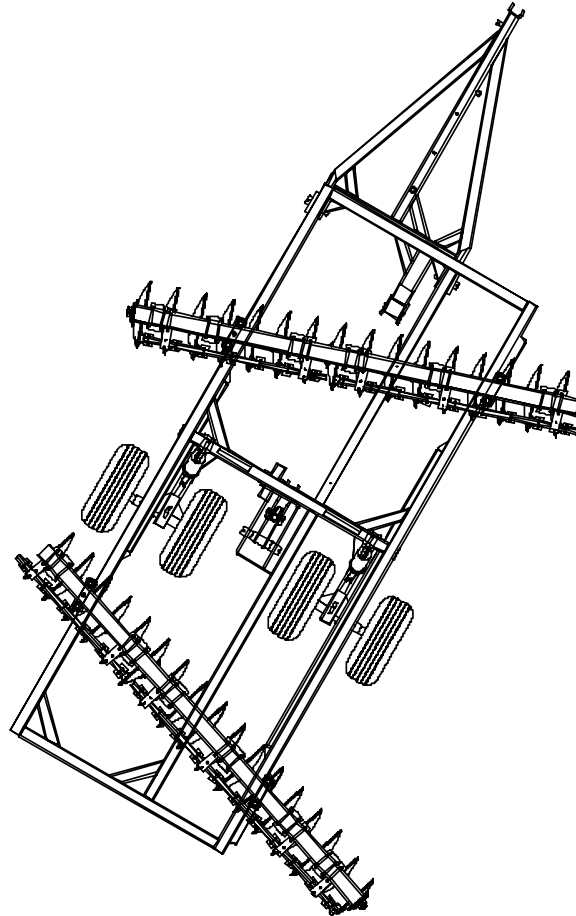

1. Raise front gang and lower rear gang with leveling screw.
2. Decrease front gang angle.
3. Increase rear gang angle.

The offset disc may be turned to the left with the disc in the ground. However, for right hand turns, the disc must be raised out of the ground.

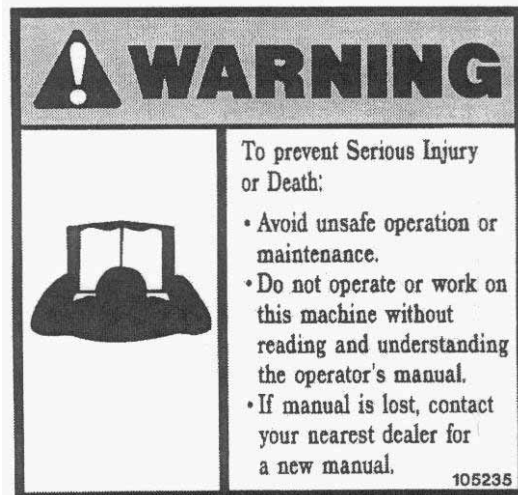



## **DEPTH CONTROL – PURGING THE REPHASING ROKSHAFT CYLINDERS**

With the invention of the rephrasing type hydraulic cylinders, large and wide machines can be built without having large and long rockshaft linkages. This reduces excess torque or rockshaft twist, fewer wear points and linkages that require servicing and replacement, and much easier leveling and adjustment.

With the cylinders working in unison, uniform depth can be obtained.

However, since the oil must have travel through the entire system (the oil is the only way to keep the system in “phase”) it is important when you hook up your tractor hydraulics that all the air which may be present at each hookup is taken out of the system. This is referred to as “purging the system”.

Purge all depth cylinders by holding the hydraulic level in the up (extend) position for three (3) minutes. Lower the machine. Raise the machine and hold the lever in the up position again for another three (3) minutes.

### **OTHER NOTES ON PURGING AND REPHASING CYLINDERS**

If air is left in the rephrasing system, several things can happen. For example, as a machine is lowered into the ground, one wheel does not move immediately or lags behind the others, or when operating in the field and a cylinder may seem to be creeping off the stop. When air is in a hydraulic system, it acts like an invisible spring and when the weight is off the cylinder, this “spring” pushes the cylinder out. Ninety-eight percent of all rockshaft cylinder problems are due to air in the system. It is a recommended procedure to raise the machine to its full height and hold the lever for a few minutes each time the machine is attached to the tractor, and several times during the day, such as when it is raised to make a turn. This assures a fresh supply of oil will continually purge the system of air. Purging is done only when the cylinders are completely extended.

When relieving the pressure on the hydraulic line at the end of the day, or when uncoupling the hydraulic tips, lower the machine with the tractor running until the cylinders reach the stops or the road stops. If the machine is lowered with the tractor not running, no oil is pumped back into the system, causing the possibility of air getting back into the rephrasing system.

**! WARNING**



**OVERHEAD WING HAZARD**

To prevent Serious Injury or Death:

- Stay away from beneath wings when they are in the raised position or are being lowered.
- Keep others away.

105234

**! CAUTION**

**RELEASE LOCK-UP BRACKETS  
BEFORE LOWERING WINGS.**

104158

# REGISTRATION CARD

This card is to be completed and forwarded to:

# WISHEK MFG. L.L.C.

P.O. Box 185 Wishek, ND 58495-0185

UNIT MODEL NUMBER \_\_\_\_\_

UNIT SERIAL NUMBER \_\_\_\_\_

PURCHASERS NAME \_\_\_\_\_

ADDRESS \_\_\_\_\_

\_\_\_\_\_

TELEPHONE (        ) \_\_\_\_\_

DATE OF PURCHASE \_\_\_\_\_

## DEALER NAME, ADDRESS & PHONE NUMBER

\_\_\_\_\_

\_\_\_\_\_

\_\_\_\_\_

\_\_\_\_\_

SALESPERSON \_\_\_\_\_

Cut along dotted line after completion and return  
to the manufacturer upon purchase